



FAATS-1000 FAN ARRAY AIRFLOW TOTALIZING SYSTEM

DESCRIPTION

The **FAATS-1000** Fan Array Airflow Totalizing System has been specifically designed to provide a cost effective means for accurate ($\pm 0.25\%$ F.S.) airflow measurement of up to forty individual fans within a single fan array or forty combined fans in an air handling unit with both supply and return fan arrays. The **FAATS-1000** utilizes either existing airflow sensors provided by the fan manufacturer or field installed airflow sensors as inputs to each fan's independent airflow transducer.

The individual airflow rate of each fan in an array is indicated on a seven inch, full color, Human-Machine-Interface (HMI) touch screen panel as well as the summed (total) airflow rate of each array. The total airflow rate of each array is also made available to the Building Management System (BMS) via dedicated field selectable 0 to 5 VDC, 0 to 10 VDC, or 4 to 20 mA analog outputs. Individual fan airflow rates and total airflow rates for each array are also available to the BMS via BACnet®-MS/TP Master or Modbus® RTU Slave network communications.

Independent monitoring of each fan allows the **FAATS-1000** to identify and alarm fan failures and airflow rate discrepancies between fans. All caution alarms and failure alarms are available to the BMS for facility operator notification.

The **FAATS-1000's** intuitive on screen menus and custom "HELP" pages have been developed to facilitate field programming and setup changes that may be required.

A remote transducer panel is also available to minimize the pneumatic tubing required for **FAATS-1000** systems measuring both supply and return fan arrays. The main **FAATS-1000** panel and the remote transducer panel are connected via a CAT5 cable supplied by others.

Features

- Individual monitoring of up to forty fans
- 24 VAC/VDC power
- Resettable fuse & power switch
- Seven inch HMI color touch screen display
- Local display of each fan's airflow rate as well as the total airflow rate for each array
- $\pm 0.25\%$ F.S. transducer accuracy
- Excellent resolution utilizing a 16 bit A/D converter (65,536 steps)
- Five point linearization capability
- Two alarm relay outputs (SPDT)
- Fan failed and fan caution alarm functions
- Field selectable analog outputs (0-5 VDC, 0-10 VDC, or 4-20 mA) scaled linear to the total measured airflow rate of each fan array
- BACnet®-MS/TP Master or Modbus® RTU Slave communication protocols
- Two levels of password protection
- Simple field configuration menus
- Single point temperature and altitude input for air density correction
- Field configurable for either English or SI units
- NEMA 1 rated enclosure (standard)
- NEMA 4X rated enclosure (optional)
- Remote transducer panel for systems measuring both supply and return fan arrays (optional)

FAATS-1000 Technical Specifications

Transducer

- 1. Accuracy**
±0.25% of full scale including linearity, hysteresis, deadband and repeatability
- 2. Operating Range**
The operating range is calculated using 30% to 100% of the value entered as full scale range at factory calibration. The operating value entered will represent full scale process output of 5 VDC, 10 VDC, or 20 mA
- 3. Temperature Effect**
Zero: 0.03% of transducer full span per °F
Span: 0.03% of transducer full span per °F
- 4. Temperature Limits**
Operating: 32 to 113°F (0 to 45°C)
Storage: 14 to 140°F (-10 to 60°C)
- 5. Overpressure Limits**
Proof Pressure: 7.25 psid
Burst Pressure: 10 psid
- 6. Humidity Limits**
0 to 95% RH, non-condensing

- 7. Mounting Position Effect**
≤ 0.25% full scale
- 8. Zero Adjustments**
Performed via display menus
- 9. Display Low Pass Filter**
Response time to reach 98% of a step change is menu adjustable with two separate rolling average adjustments, sample interval and number of samples)
- 10. Output Low Pass Filter**
Response time to reach 98% of a step change is menu adjustable with two separate rolling average adjustments, sample interval and number of samples)
- 11. Programmable Constants**
Constants such as temperature, barometric pressure (altitude), area factor etc. can be easily entered via display menus

Indication

- 12. Display**
LED backlit, 7 inch HMI 800 x 480 touch screen display

Communication

- 13. Network**
BACnet MS/TP® Master
Modbus® RTU Slave

Inputs/Outputs

- 14. Analog Outputs**
Fan Array 1: Process Output signal, switch selectable 0 to 5 VDC, 0 to 10 VDC, or 4 to 20 mA (Max. load 700Ω). If configured for a single array system, both output channels can be used.
Fan Array 2: Process Output signal, switch selectable 0 to 5 VDC, 0 to 10 VDC, or 4 to 20 mA (Max. load 700Ω)
- 15. Digital Inputs**
Group 1 - Dry Contact
Group 2 - Dry Contact
Group 3 - Dry Contact
Group 4 - Dry Contact
- 16. Digital Outputs**
Fan Array 1 Alarm: two single (1 form C) dry contacts rated for 5 amps at 30 VAC/VDC and 10 amps at 120 VAC resistive load
Fan Array 2 Alarm: two single (1 form C) dry contacts rated for 5 amps at 30 VAC/VDC and 10 amps at 120 VAC resistive load

Power

- 17. Power Supply**
20 to 28 VAC/VDC
- 18. Power Consumption**
Standard Unit with HMI, CPU and one 8 Sensor Module: 27 VA
Each additional 8 Sensor Module: 5.28 VA
- 19. Circuit Protection**
Power input is isolated, reverse polarity protected and supplied with a resettable fuse

Enclosure

- 20. UL & CSA Rating**
NEMA 1 (standard)
Material: Steel
NEMA 4X (optional)
Material: Steel

FAATS-1000 And Remote Transducer Panel Dimensions

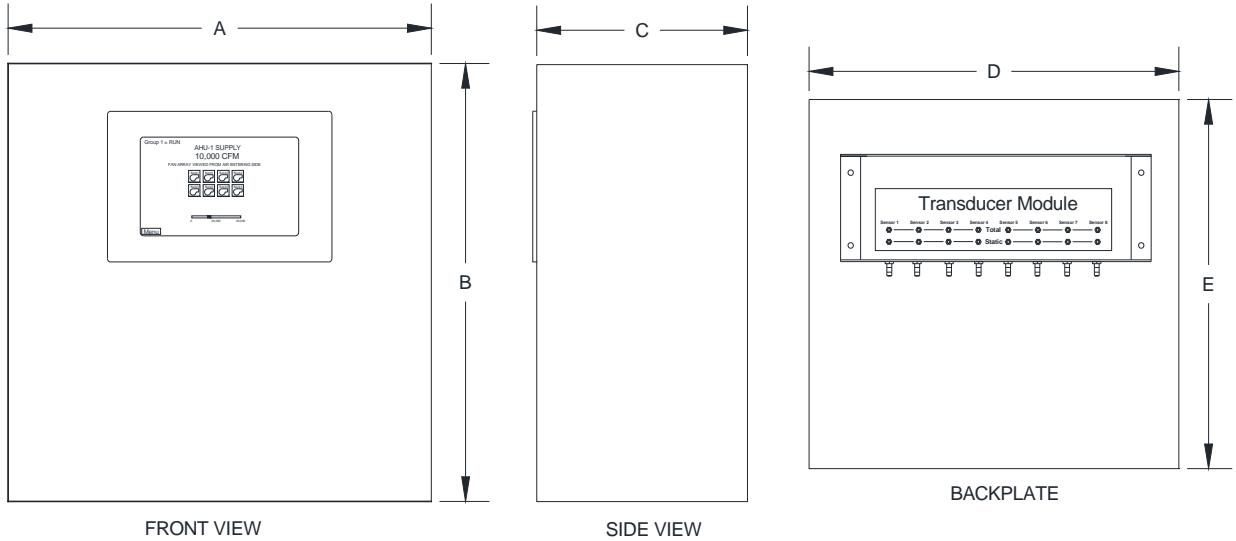

Number of Fans	Number of Transducer Modules	Dimension (inches)				
		A	B	C	D	E
2 - 8	1	16	16	8	14	13
9 - 16	2	20	24	8	18	19
17 - 24	3	24	30	8	22	28
25 - 32	4	24	36	8	22	34
33 - 40	5	30	36	8	28	34

FAATS-1000 Electrical Connections

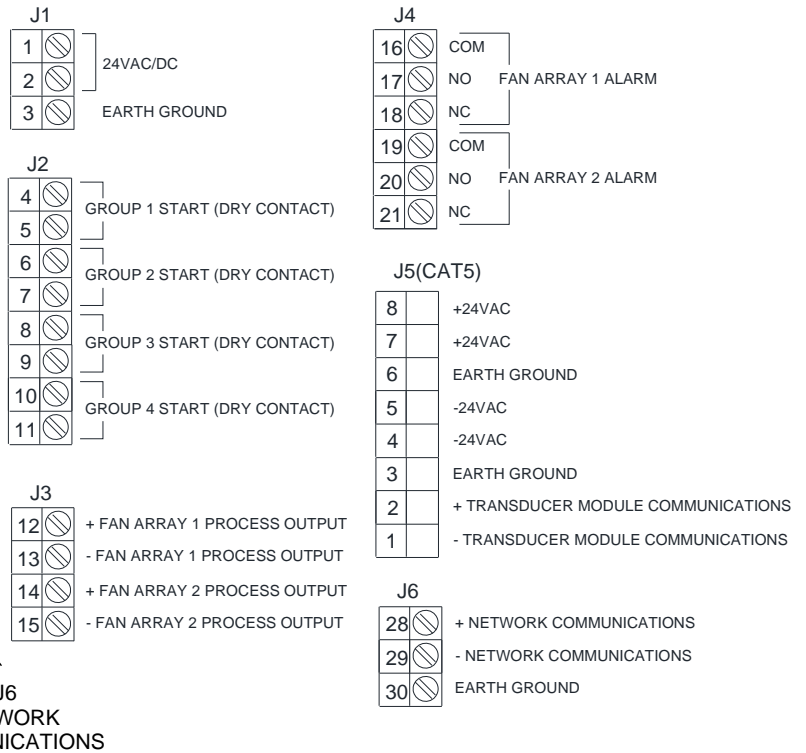
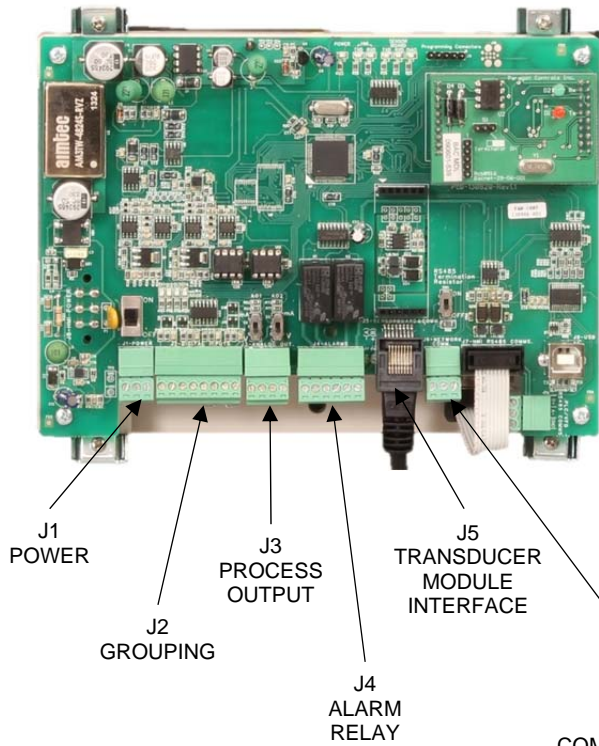

FAATS-1000 Pneumatic Connections

The FAATS-1000 can monitor and alarm up to 40 fans configured as a single array or a dual array. The Transducer Modules are in groups of 8 sensors per module (Example: 12 fan system would require 2 Transducer Modules). Viewing the fan array from the air entering side, the plumbing sequence would start from the upper left fan (Sensor 1) and continue to the end of the first row. The count sequence would continue on the left side of the second row until all fans are counted. The picture below shows a typical Enclosure Layout for an 8 Fan Array System. A larger fan system would have more transducer modules in a larger enclosure.



Sensor 1
(Fan 1)

Sensor 8
(Fan 8)

Single Array Pneumatic Connection Layout

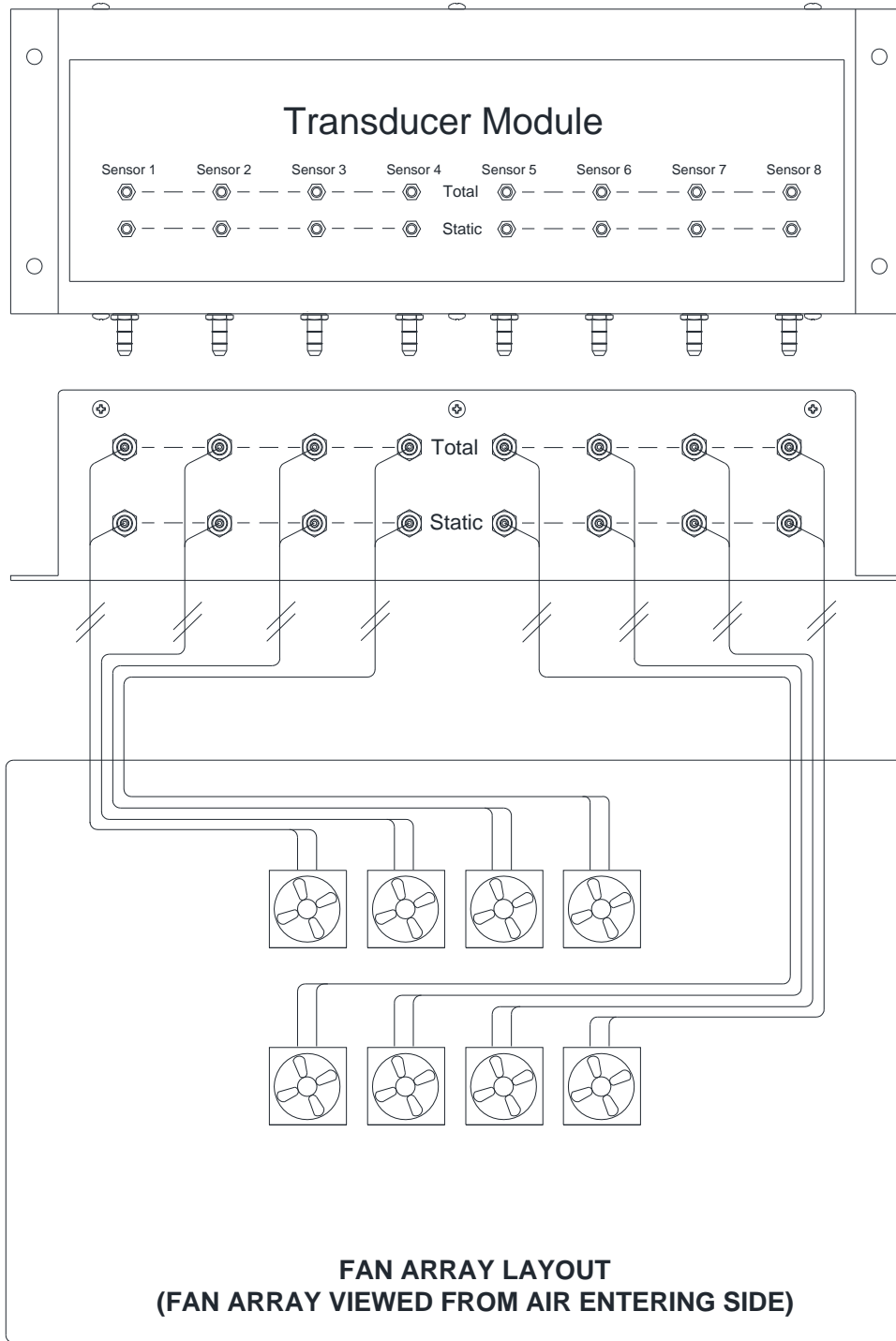

Dual Array Pneumatic Connection Layout

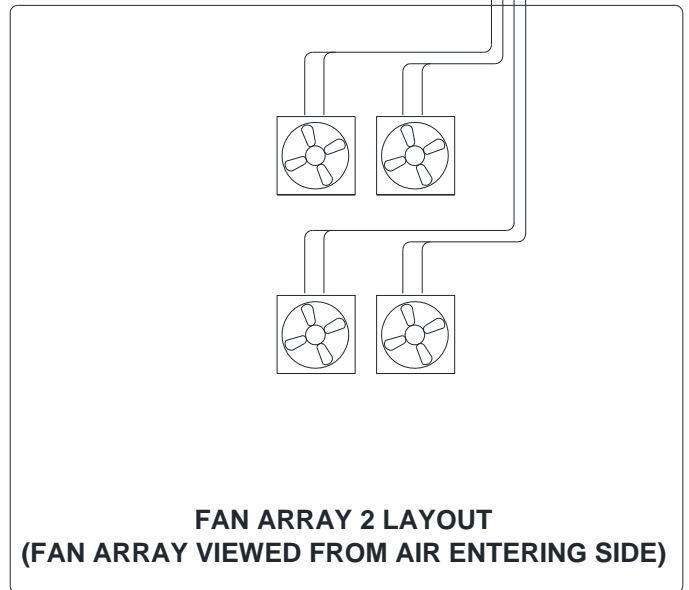
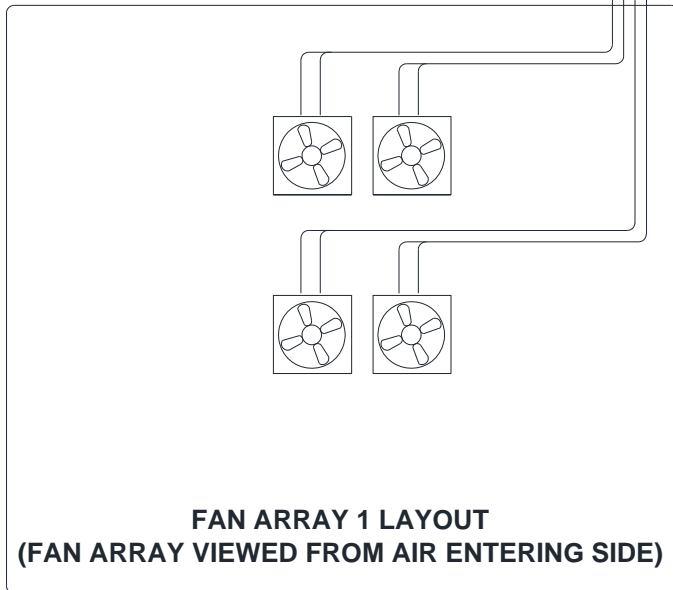
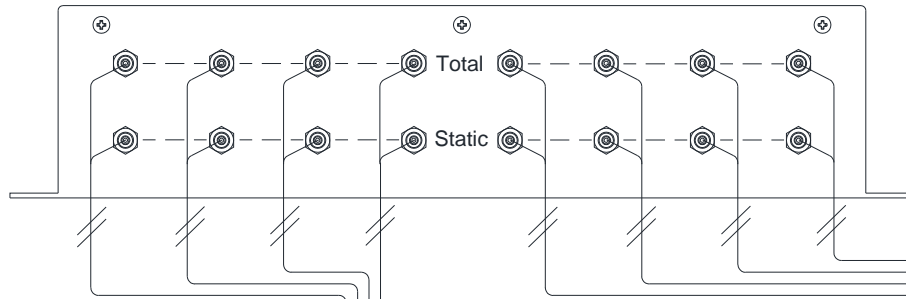
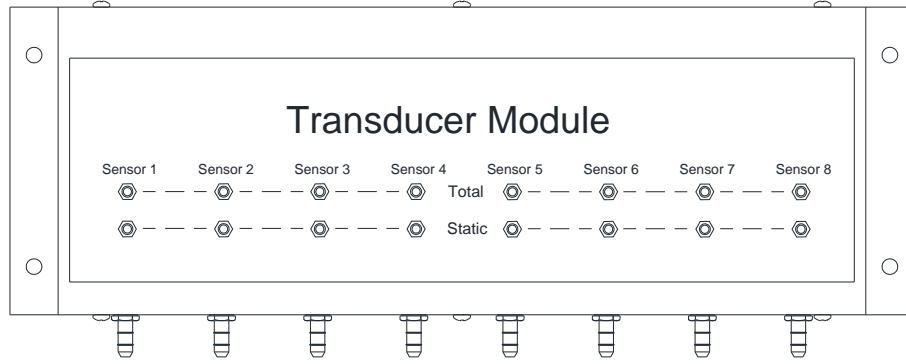

FAATS-1000 Specification Guide

Multiple Fan (Fan Array) Applications:

1. When multiple fans (fan array) are serving a common duct, the air handling manufacturer shall provide airflow measurement pressure taps for each individual fan and shall provide the factory determined flow coefficient for the fans being furnished. The building automation system (BAS) contractor shall furnish and install a fan array airflow totalizing system which monitors the airflow capacity of each individual fan based on the differential pressure and flow coefficient, and shall provide a totalized airflow rate to the BAS for control and monitoring purposes.
2. Basis of design shall be Paragon Controls Incorporated's Fan Array Airflow Totalizing System Model FAATS-1000 subject to compliance with the following stated requirements or an equal as approved by the Engineer.
3. Accuracy shall be 0.25% of full scale including non-linearity, hysteresis, deadband and non-repeatability for each fan in the array.
4. All airflow rate calculations shall be based on the fan manufacturers specified flow coefficient, jobsite elevation, and air temperature.
5. The airflow totalizing system shall utilize a 16-bit or greater analogue to digital converter for precise conversion of the differential pressure input from each fan and a 12 bit or greater digital to analogue converter providing high resolution output to the BAS control system.
6. Analog outputs to the BAS control system shall be linear to the measured total airflow rate of each fan array. Analog outputs shall be field selectable allowing for [4-20 mA] [0-5 VDC] [0-10 VDC] transmission signal to the BAS for control and monitoring purposes.
7. The fan array monitoring system shall utilize a human-machine-interface (HMI) panel for air volume indication and configuration of the fan array airflow totalizing system.
8. The HMI shall provide continuous on screen indication of each individual fan's airflow rate and operational status, and shall display the totalized airflow rates for each fan array numerically and graphically as a percent of total design flow. The graphic screen shall be configured to match the fan array layout (i.e. two rows by three columns for a total of six fans).
9. The fan array monitoring system shall provide individual fan diagnostics via the HMI panel. In this mode the display shall indicate the measured differential pressure being reported by each individual fan as well as transducer output.
10. Automatic zero and span calibration of each individual differential pressure transducer shall be performed via the HMI.
11. The fan array monitoring system shall provide individual fan failure alarming capability. The alarming function shall provide a warning alarm when an individual fan's airflow rate is either above or below the average for all fans by a programmable percentage value. A failed fan alarm shall be initiated when the airflow rate for an individual fan goes to zero. The fan (or fans) that are in an alarm state shall be shown on the HMI graphics screen in flashing yellow for warning and red for failed.
12. The fan array airflow totalizing systems shall provide network communication to the BAS for monitoring and control purposes via [BACnet®-MS/TP Master] [Modbus®RTU Slave] communication network. The network information shall provide individual fan information and remote configuration of all programmable values.

